



CE

ETA-18/0104

# HMR 750

Tension Rod System | Compression Strut System

A strong connection that lasts.

[hmr-jacob.de](http://hmr-jacob.de)



The image shows a detailed view of a tension rod system. A long, silver-colored rod is shown at an angle. A smaller, cylindrical component is shown in a disassembled state, revealing internal threads and a spring. A larger, complex metal component, likely a bracket or anchor, is shown below the rod. Orange circles highlight specific features on each part, with lines connecting them to a central point. The background is dark blue, and the bottom of the image is white.

# **INNOVATION IN A TENSION ROD SYSTEM**



### Data Matrix code

Is used for individual bar marking and quality assurance



### Sealant injection holes

Prevents crevice corrosion



### Special corrosion protection on bar thread area

Class C3 high corrosion compliant



### Easy control of thread engagement

For safer installation



### Blind hole

Improves corrosion protection



### Very high load capacities



**ISO 9001:2015**  
Quality Management System  
Certificate by DEKRA



**EN 1090-2:2018 EXC4**  
Welding Certificate for  
Execution of structural steel  
components by SLV Munich



**OHRIS Zertifikat Nr. 09-00553**  
Management System Certificate for  
Occupational Health and Plant Safety  
by the Bavarian State Ministry of Family,  
Labour and Social Affairs

#### Further Certifications:

In-house UT2-controller for ultrasonic inspections,  
MT2-controller for magnetic particle testings,  
VT2-controller for visual examinations and  
PT2-controller for dye penetrant testings  
to guarantee quality assurance of all manufactured  
and deliverable components



# HMR750 Tension Rod System

The HMR 750 tension rod system offers modern architecture, an innovative and elegant design, improved corrosion protection, higher capacity loads and improved safety during installation.

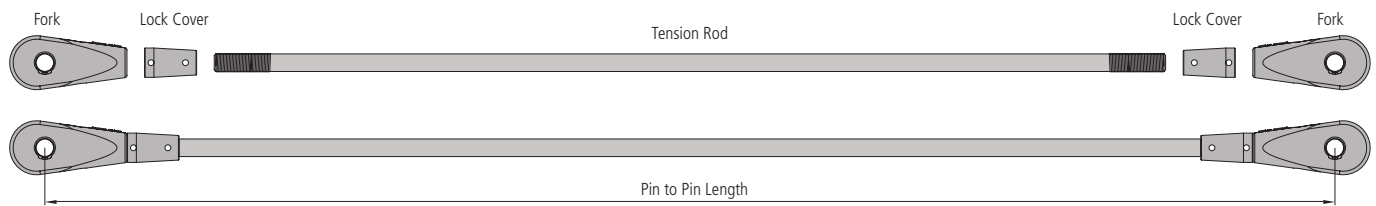

## Mechanical Properties

Thread size	Unit	M12	M16	M20	M24	M30	M36	M42	M48	M56	M64	M76	M85	M90	M100	
Minimum Yield Stress	N/mm <sup>2</sup>	540						540								
Minimum Breaking Stress	N/mm <sup>2</sup>	720						750								
Min. Elongation	%	17						17								

## Capacity Loads

Thread size	Unit	M12	M16	M20	M24	M30	M36	M42	M48	M56	M64	M76	M85	M90	M100
Bar diameter	mm	12	15	19	23	28	34	40	45	54	62	74	83	90	100
Capacity Load	kN	43	81	126	182	290	423	605	795	1157	1539	2213	2799	3154	3928
Bar weight	kg/m	0,89	1,39	2,23	3,26	4,83	7,13	9,87	12,49	17,98	23,70	33,76	42,47	47,75	61,65
Maximum bar length	mm	7,850	8,850	11,800											

Capacity loads of tension rods as per DIN EN 1993-1-8, Table 3.4 and DIN EN 1993-1-1 section 6.2.3 with partial safety factors  $\gamma_{M0} = 1,0$  and  $\gamma_{M2} = 1,25$

Longer lengths can be achieved by using coupler or turnbuckle joints.  
All system components are designed to take the full capacity of the tension rod.

## Length Adjustments / Minimum thread engagement

Thread size	Unit	M12	M16	M20	M24	M30	M36	M42	M48	M56	M64	M76	M85	M90	M100
<b>System with two fork connectors</b>	mm	± 12	± 16	± 20	± 24	± 30	± 36	± 42	± 48	± 56	± 61	± 71	± 78	± 80	± 85
Turnbuckle	mm	± 20	± 25	± 25	± 30	± 30	± 40	± 40	± 40	± 50	± 50	± 50	± 50	± 60	± 60
Cross Coupler	mm	± 11	± 15	± 16	± 19	± 22	± 27	± 32	± 35	± 42	± 48	± 57	± 62	± 67	± 74

The pin to pin length is the distance between the centre of each pin. Once installed the tendons can be adjusted by rotating the rod.  
Further adjustment can be achieved by using a turnbuckle.

## Corrosion Protection

HMR tension rod systems are available in the following surface finishes:

**Carbon steel\*** ■ Hot dip galvanised ■ Powder coated ■ Painted ■ Duplex coated

\* All fittings are supplied in a hot dip galvanised finish to EN 1461.

# System Overview

Whether it be truss systems, back-braced façades, suspensions or cross bracings' the diversity of applications of HMR750 tension rods provide a high-quality solution for virtually any application.

## Basic system

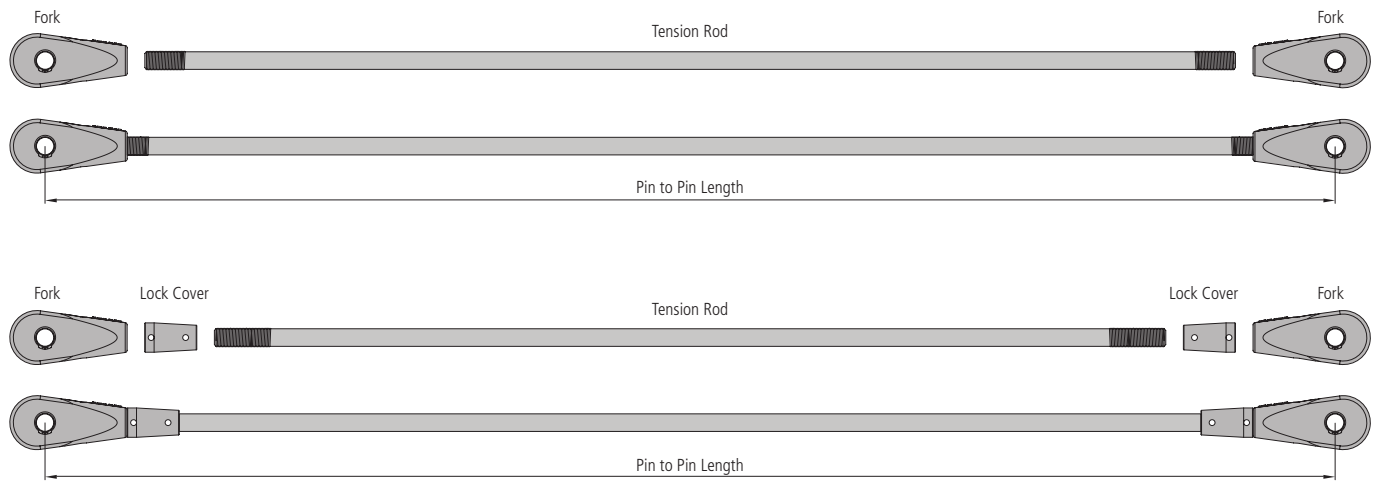

## System with coupler

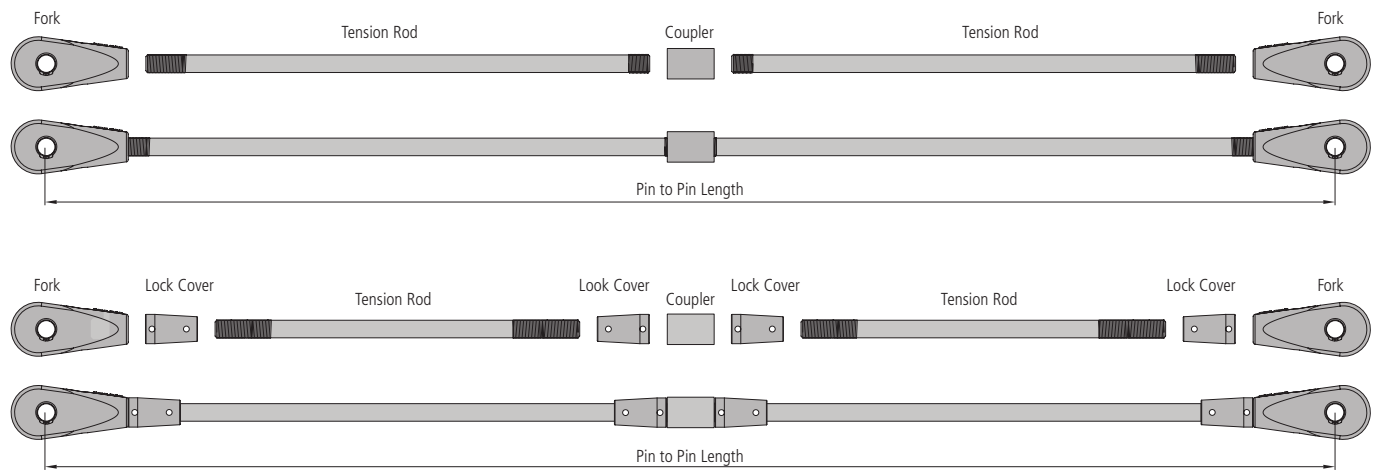

# System Overview

## System with turnbuckle

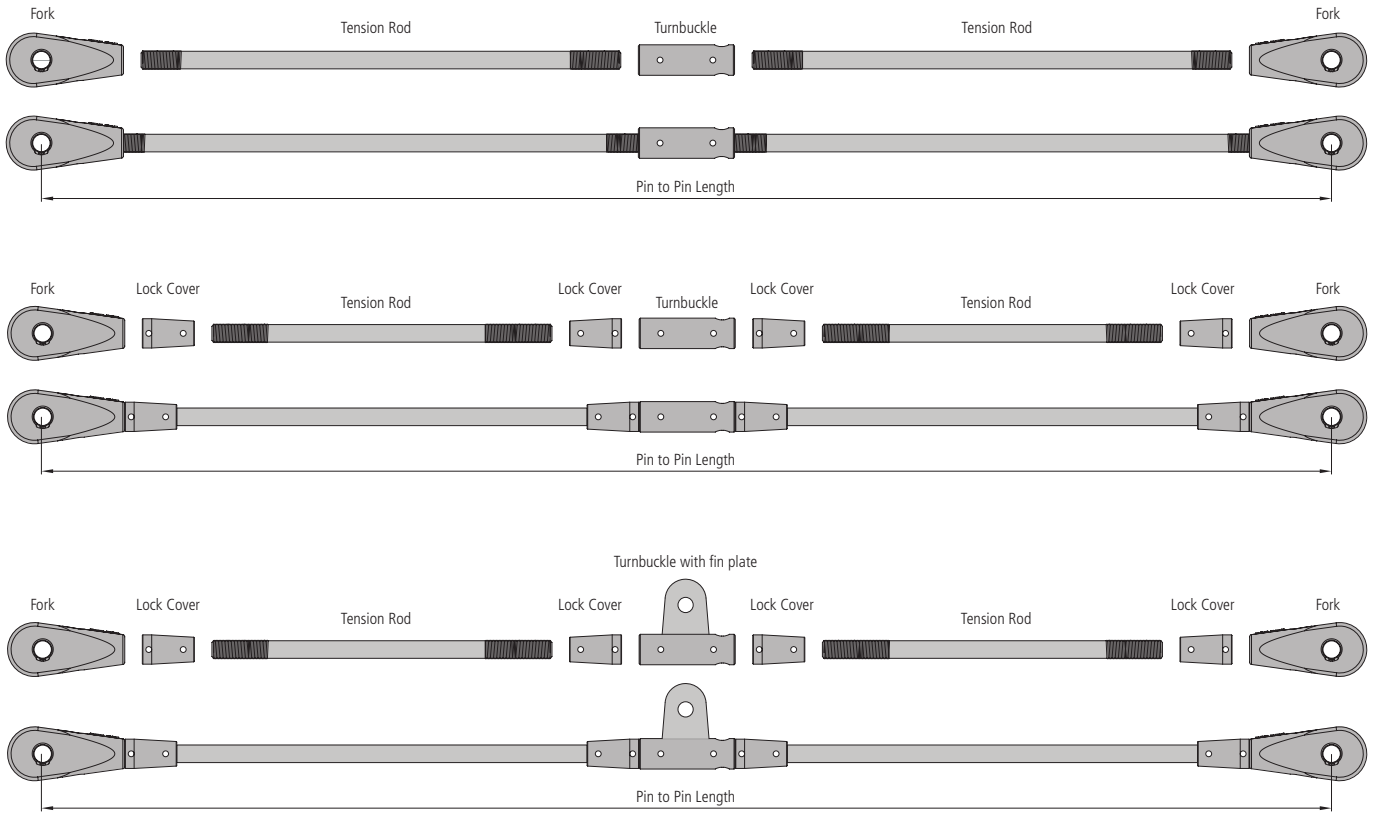

## Cross Bracings

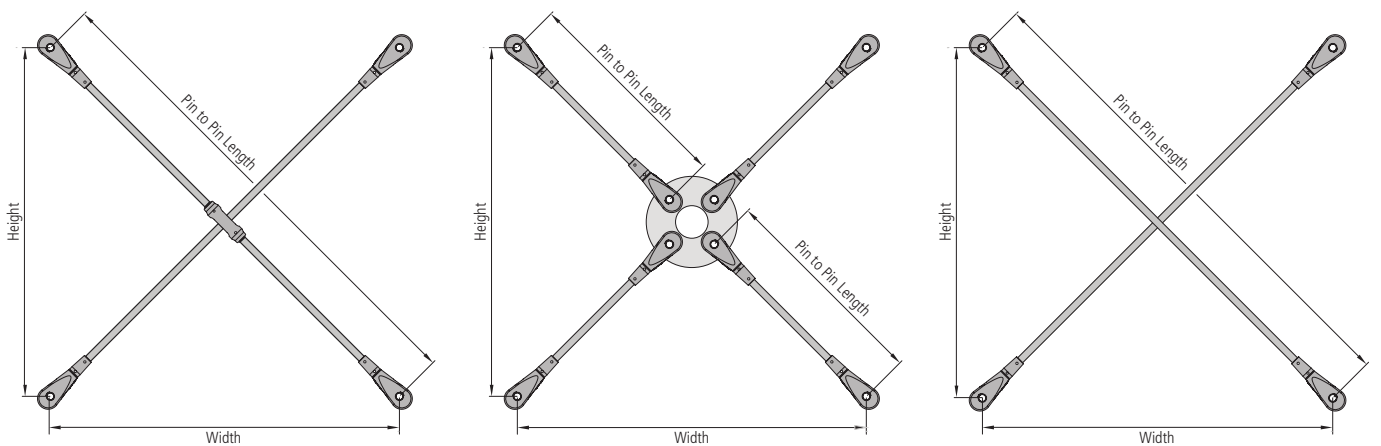

With Cross Coupler

With Connection Disc

Basic Cross Bracing

# HMR Compression Strut System

In addition to our innovative product range, HMR have introduced an architectural compression strut system which can be perfectly integrated into any structural application.

Compression struts consist of standard fork connectors plus a circular hollow section with a welded tapered cone at each end. Threaded studs are used to connect the forks with the tapered hollow section. The system is designed to enable transmission of both tensile or compressive forces.

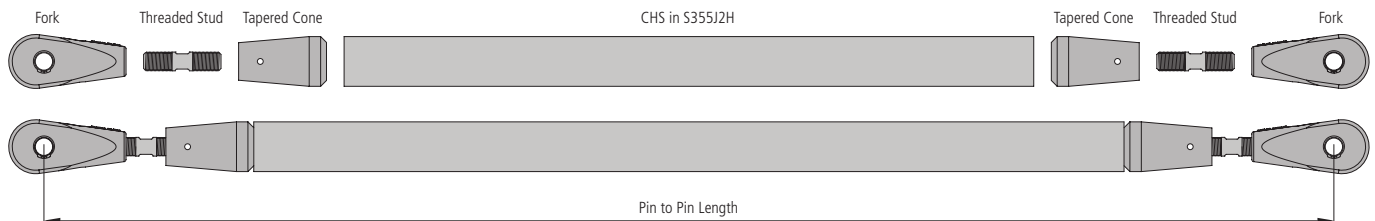

## CHS sizes

Fork size	M12	M16	M20	M24	M30	M36	M42	M48	M56	M64	M76	M85	M90	M100
Recommended CHS Ø (mm)	33,7	42,4	60,3	76,1	88,9	114,3	139,7	168,3	193,7	219,1	244,5	323,9	323,9	323,9
Wall thickness (mm)	4	5	5	5	5	6,3	10	10	10	12,5	16	16	16	16

## Maximum Capacities (kN)

Pin-to-pin length (m)	M12	M16	M20	M24	M30	M36	M42	M48	M56	M64	M76	M85	M90	M100
1 (max. compressive force)	16	62	100	149	241	360	520	691	995	1334	1934	2427	2753	3408
2	16	37	100	149	241	360	520	691	995	1334	1934	2427	2753	3408
3	9	17	62	125	194	360	520	691	995	1334	1934	2427	2753	3408
4	-	10	36	74	119	297	520	691	995	1334	1934	2427	2753	3408
5	-	6	24	49	79	203	520	691	995	1334	1934	2427	2753	3408
6	-	-	17	34	56	145	388	666	973	1334	1934	2427	2753	3408
7	-	-	12	26	41	109	293	512	765	1296	1934	2427	2753	3408
8	-	-	-	20	32	85	229	403	610	1049	1748	2427	2753	3408
9	-	-	-	16	26	67	183	324	494	857	1445	2427	2753	3029
10	-	-	-	13	21	55	150	266	407	711	1206	2427	2630	2630
11	-	-	-	11	17	45	125	222	341	597	1017	2278	2278	2454
12	-	-	-	-	15	39	105	188	290	508	868	1978	1978	1978

Notes: Compressive load is calculated according to EN 1993. In all cases a structural calculation should be carried out by the contractor.

## Length adjustments

	M12	M16	M20	M24	M30	M36	M42	M48	M56	M64	M76	M85	M90	M100
System with two fork connectors (mm)	± 12	± 16	± 20	± 24	± 30	± 36	± 42	± 48	± 56	± 64	± 76	± 85	± 90	± 100

The pin to pin length is the distance between the centres of the pins.  
The exact length can be set by rotating the spanner flat on the threaded stud.

## Corrosion Protection

HMR Compression struts can be supplied in the following surface finishes:

**Carbon steel\*** ▪ Galvanised ▪ Powder coated ▪ Painted ▪ Duplex coated

\* Fork and pin are supplied in a hot dip galvanised finish to EN 1461. Threaded studs are supplied in a galvanised coating.

# System Components

The slim and elegant design of our system components guarantees a smooth transition to the tension rod. This allows a perfect fit into any form of architectural concept such as steel, timber and glass façade constructions.

## Fork

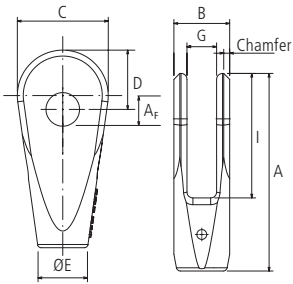

Thread size	M12	M16	M20	M24	M30	M36	M42	M48	M56	M64	M76	M85	M90	M100
Thread pitch	1.75	2	2.5	3	3.5	4	4.5	5	4	4	4	4	4	4
A <sub>f</sub> (mm)	13	17	23	27	33	39	45	51	60	68	80	93	98	113
A (mm)	77	100	122	144	181	210	246	279	334	378	444	509	534	611
B (mm)	22,0	28,2	36,8	44,0	50,4	65,0	76,6	89,2	99,8	119,6	150,0	155,4	174,2	179,2
C (mm)	35	46	55	66	83	97	112	127	151	174	207	243	255	298
A <sub>D</sub> (mm)	23	30	36	44	55	64	72	83	100	115	136	153	163	188
E (mm)	19	25	29	35	44	52	60	69	80	91	108	121	129	143
G (mm)	12	15	18	23	25	33	38	43	48	59	74	74	84	89
I (mm)	48	63	77	91	116	133	157	178	217	245	287	334	349	406
M <sub>EL</sub> (mm)	18	24	30	36	45	54	63	72	84	94,5	111,5	124	130	142,5
A <sub>f</sub> ⇒ Pin hole diameter Ø (± 0,50 mm)    M <sub>EL</sub> ⇒ medium screw-in depth														

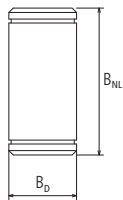

## Pin with circlip (standard)

Thread size	M12	M16	M20	M24	M30	M36	M42	M48	M56	M64	M76	M85	M90	M100
B <sub>D</sub> (mm)	12,0	16,0	21,0	25,0	31,0	37,0	43,0	49,0	58,0	66,0	78,0	91,0	95,0	110,0
B <sub>NL</sub> (mm)	31,6	38,8	49,0	57,2	67,0	82,2	96,8	112,0	122,6	145,4	175,8	183,2	203,0	211,2
B <sub>D</sub> ⇒ diameter Ø    B <sub>NL</sub> ⇒ length														

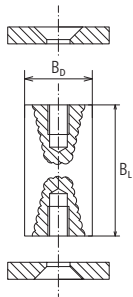

## Pin with washer (on request)

Thread size	M12	M16	M20	M24	M30	M36	M42	M48	M56	M64	M76	M85	M90	M100
B <sub>D</sub> (mm)	12,0	16,0	21,0	25,0	31,0	37,0	43,0	49,0	58,0	66,0	78,0	91,0	95,0	110,0
B <sub>L</sub> (mm)	25	31	40	47	53	68	81	93	104	126	156	161	181	186
B <sub>D</sub> ⇒ Diameter Ø    B <sub>L</sub> ⇒ Length														

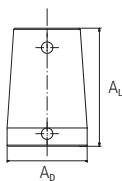

## Lock cover

Thread size	M12	M16	M20	M24	M30	M36	M42	M48	M56	M64	M76	M85	M90	M100
A <sub>D</sub> (mm)	19	25	29	35	44	52	60	69	80	91	108	121	129	143
A <sub>L</sub> (mm)	36,3	44,4	51,0	57,6	67,0	80,4	89,8	99,2	110,4	120,6	135,4	148,0	152,0	161,0
A <sub>D</sub> ⇒ Diameter Ø    A <sub>L</sub> ⇒ Length														



Pedestrian bridge across the laguna at Kluczbork, Poland (Zem Labydy)



Pedestrian and cyclist bridge across the Innbach river at Alkoven, Austria (Corporation of Alkoven)

# System Components

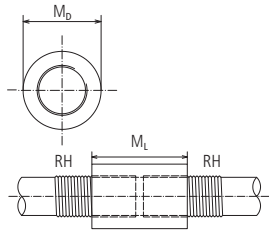

## Coupler

Thread size	M12	M16	M20	M24	M30	M36	M42	M48	M56	M64	M76	M85	M90	M100
M <sub>D</sub> (mm)	20	26	32	38	47	56	66	75	87	99	119	135	143	160
M <sub>L</sub> (mm)	32	40	48	56	68	80	92	104	120	136	160	178	188	208
M <sub>D</sub> ⇒ Diameter Ø    M <sub>L</sub> ⇒ Length														

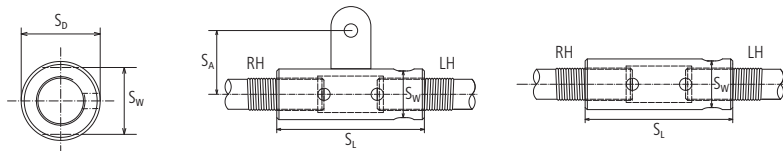

## Turnbuckle (also with fin plate)

Thread size	M12	M16	M20	M24	M30	M36	M42	M48	M56	M64	M76	M85	M90	M100
S <sub>D</sub> (mm)	20	26	32	38	47	57	67	76	90	103	122	137	145	161
S <sub>L</sub> (mm)	64	82	90	108	120	152	164	176	212	228	252	270	300	320
S <sub>W</sub> (mm)	18	23	28	32	41	50	60	70	80	92	112	125	135	150
Einstellbereich (mm)	± 20	± 25	± 25	± 30	± 30	± 40	± 40	± 40	± 50	± 50	± 50	± 50	± 60	± 60
A <sub>L</sub> (mm)	10	10	10	10	10	10	10	12	12	12	12	15	15	15
S <sub>A</sub>	48	51	54	57	61,5	66,5	71,5	86	93	99,5	109	126,5	130,5	138,5
S <sub>D</sub> ⇒ Diameter Ø    S <sub>L</sub> ⇒ Length    S <sub>W</sub> ⇒ width across flats    A <sub>L</sub> ⇒ plate thickness S <sub>A</sub> ⇒ offset of suspension hole														

Notes: For more details concerning the fin plate, please contact HMR Jacob.



Fare Pote'e in the Vaitupa Parc at Faa'a, Tahiti (Compas)

# Gusset Plates

Tension rods are attached by sliding a gusset plate, which, in turn, is fastened to the structure in between the fork. The fabrication of gusset plate connections are subject to static and structural requirements. The design should be in line with dimensions as shown in table 12.

The plate should be fabricated in grade S355J2+N material in accordance with DIN EN 10025 .

**As part of our portfolio HMR Jacob can offer fabricated gusset plates and unique design solutions.**

**Furthermore, we supply a broad range of products within the steel construction sector.**

## Gusset plate

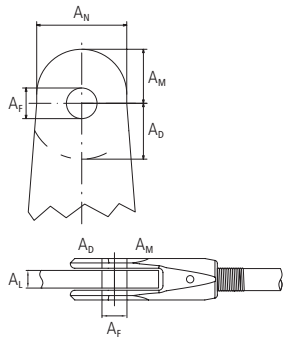

Thread size	M12	M16	M20	M24	M30	M36	M42	M48	M56	M64	M76	M85	M90	M100
A <sub>L</sub> (mm)	10	12	15	20	22	30	35	40	45	55	70	70	80	85
A <sub>F</sub> (mm)	13	17	23	27	33	39	45	51	60	68	80	93	98	113
A <sub>M</sub> (mm)	22	30	37	43	56	64	79	89	109	122	143	171	176	206
A <sub>N</sub> (mm)	35	50	60	70	90	105	128	147	178	198	232	280	288	338
D (mm)	23	30	36	44	55	64	72	83	100	115	136	153	163	188

A<sub>L</sub> ⇒ Thickness    A<sub>F</sub> ⇒ Pin hole diameter Ø (± 0,50 mm)  
 A<sub>M</sub> ⇒ Clearance (+2/-0 mm)    A<sub>N</sub> ⇒ Minimum width  
 A<sub>D</sub> ⇒ clearance refers to dimension D (Fork Table, page 8)

When installing the Tension Rod System ensure that the maximum misalignment does not exceed 0,5°. Forks should be kept in plane to each other. This prevents bending on the forks and gusset plates. For bigger misalignment, please contact HMR Jacob.

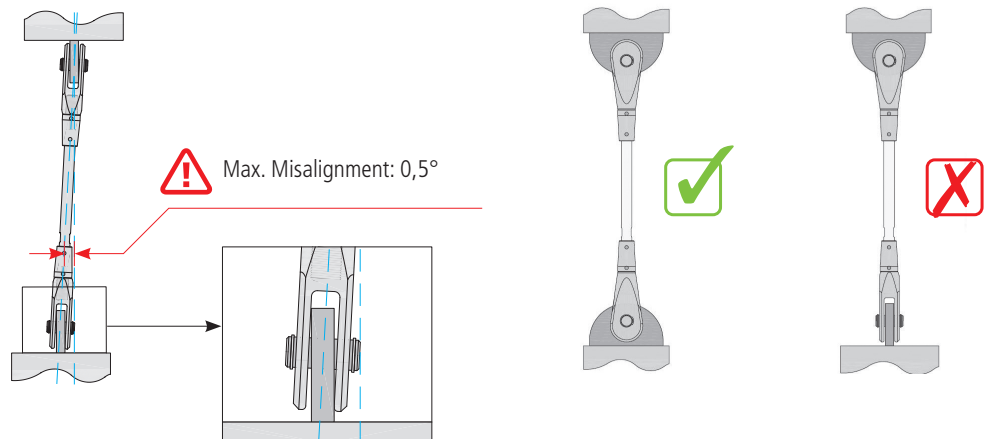

Adventure wooden sphere at Steinberg am See, Germany (Hess Timber)



Pedestrian bridge across the laguna at Kluczborok, Poland (Zem Labedy)

# Cross Bracings

Cross bracings provide stability to a structure and have the ability to resist horizontal forces. Components such as connection discs or cross couplers provide attractive connection solutions for bracing applications. HMR cross couplers offer a more cost-effective and streamlined alternative by minimising the number of fork connectors required.

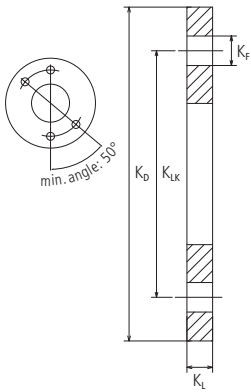

## Connection Disc

Thread size	M12	M16	M20	M24	M30	M36	M42	M48	M56	M64	M76	M85	M90	M100
$K_L$ (mm)	10	12	15	20	22	30	35	40	45	55	70	70	80	85
$K_F$ (mm)	13	17	23	27	33	39	45	51	60	68	80	93	98	113
$K_D$ (mm)	151	196	233	274	350	402	477	541	644	740	869	1029	1071	1243
Inner Diameter (mm)	50	70	80	90	120	140	160	180	230	250	300	350	375	400
$K_{LK}$ (mm)	107	136	159	188	238	274	319	363	426	496	583	687	719	831

$K_L$   $\Rightarrow$  Thickness = AL (Tabelle 13, Seite 10)  
 $K_F$   $\Rightarrow$  Pin hole diameter  $\varnothing$  ( $\pm 0,50$  mm)     $K_D$   $\Rightarrow$  Overall Diameter    Inner Diameter     $K_{LK}$   $\Rightarrow$  Diameter of outer holes  $\varnothing$

## Cross Coupler

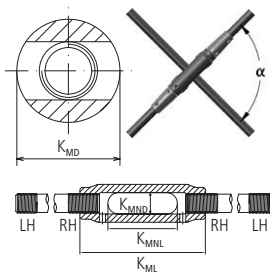

Thread size	M12	M16	M20	M24	M30	M36	M42	M48	M56	M64	M76	M85	M90	M100
$K_{MD}$ (mm)	23	31	38	46	57	69	81	92	110	125	149	168	178	198
$K_{ML}$ (mm)	76	103	124	149	181	219	258	290	343	318	376	417	444	494
$K_{MNL}$ (mm)	42	57	70	85	105	127	149	169	201	155	184	207	219	244
$K_{MND}$ (mm)	13.0	17.5	21.5	26.0	32.0	38.0	44.0	50.5	59.0	67.0	79.0	89.0	94.0	105.0
Minimum angle $\alpha$	45°	45°	45°	45°	45°	45°	45°	45°	45°	60°	60°	60°	60°	60°

$K_{MD}$   $\Rightarrow$  Overall Diameter     $K_{ML}$   $\Rightarrow$  Length     $K_{MNL}$   $\Rightarrow$  slot length     $K_{MND}$   $\Rightarrow$  slot width



Storck Bicycle Store and Showroom at Wertheim, Germany (Storck Bicycle)



Adventure wooden sphere at Steinberg am See, Germany (Hess Timber)

## HMR750 – Fatigue Resistance

Dynamic projects – now feasible with the HMR750 Tension Rod System.  
For further information, please contact: [dynamic@hmr-jacob.de](mailto:dynamic@hmr-jacob.de)



New bridge at Kamyk,  
Poland (Mostmarpal Spolka)

## HMR750 – Fire Protection

Custom-made solutions for R30 fire protection projects available. Quick and simple.  
For further information, please contact: [R30@hmr-jacob.de](mailto:R30@hmr-jacob.de)



# Corrosion Protection

With its guaranteed 480 hours corrosion resistance in salt spray exposure, the HMR corrosion protection package offers durability compliant to C3 high and C4 moderate environments. This applies to the full range of the HMR tension rod system including bar threads.

HMR Jacob has introduced a new method that ensures long-term corrosion protection on bar threads that represents a galvanised coating in accordance with DIN EN ISO 1461.

## Corrosivity Categories to DIN EN ISO 12944

Corrosion class	Corrosivity	Durability (class)	Durability (years)*	Salt spray test in hours (h)	Examples of typical environments
C1 very low	very low less aggressive interior	low	2 to 5 Years	-	Heated buildings with clean atmospheres, e.g. offices, shops, schools, hotels
		moderate	5 to 15 Years	-	
		high	more than 15 Years	-	
C2 low	low less aggressive exterior/interior	low	2 to 5 Years	-	Unheated buildings where condensation may occur e.g. depots, sports halls
		moderate	5 to 15 Years	-	
		high	more than 15 Years	-	
C3 moderate	moderate moderately aggressive exterior/interior	low	2 to 5 Years	120	Production rooms with high humidity and some air pollution e.g. food-processing plants, laundries, breweries, dairies
		moderate	5 to 15 Years	240	
		high	more than 15 Years	480	
C4 high	high moderately aggressive exterior/interior	low	2 to 5 Years	240	Chemical plants, swimming pools, coastal, ship and boatyards
		moderate	5 to 15 Years	480	
		high	more than 15 Years	720	
C5-I very high (industrial)	high aggressive exterior/interior	low	2 to 5 Years	480	Buildings or areas with almost permanent condensation and high pollution
		moderate	5 to 15 Years	720	
		high	more than 15 Years	1440	
C5-M very high (marine)	very high marine exterior/interior	low	2 to 5 Years	480	Buildings or areas with almost permanent condensation and high pollution
		moderate	5 to 15 Years	720	
		high	more than 15 Years	1440	

\*Durability is no „warranty period“

## Advantages on the bar thread

- New method of corrosion protection applied
- Durability compliant to corrosion class C3 high and Class C4 moderate, see table
- No Brushing or re-rolling of the excess zinc from the thread



HMR bar threads after 480 hours of salt spray test.

## Advantages of the fork end

- Blind hole to prevent moisture to reach the bar thread
- Inspection hole to determine the minimum engagement of the bar
- Easy to apply the sealant when necessary

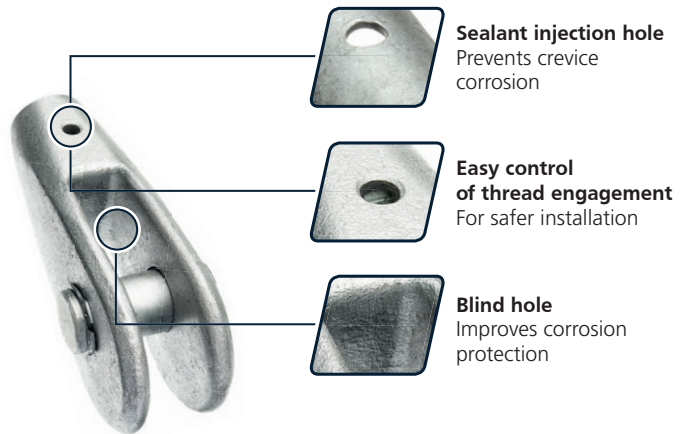
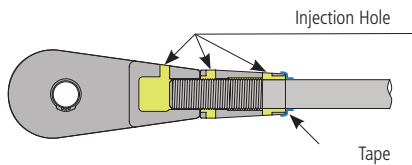

## In-house surface finishes

- One of the largest facility for powder coating in Southern Germany
- QIB-Certification according to EN 1090-2 (Steel) and EN 1090-3 (Aluminum)
- CO2-neutral coating
- Coating of galvanised steel up to corrosivity category C5-high
- Powder coating to any standard RAL colour or DB colour
- Workpieces of up to a length of 13 m, a height of 3,50 m, a width of 2,50 m and a maximum weight of 4 tons each



Tension rod systems of sizes M24-42, recently powder coated in RAL6021.

# Quality Assurance

Quality and quality assurance are the foundations of our success. Successful product development, process reliability, continuous monitoring, R&D commitment coupled with an experienced team guarantee the high quality standard of our products.

## DataMatrix code

- Production process
- Traceability of materials
- Possibility of customised data



Tension rod marking with Data Matrix code.



## Tensile testing

Brand new Tensile Test machine for all bar diameters

- In-house quality supervision on the basis of constant tests
- Monitoring of material and load capacities
- Ensuring quality products are delivered to customers

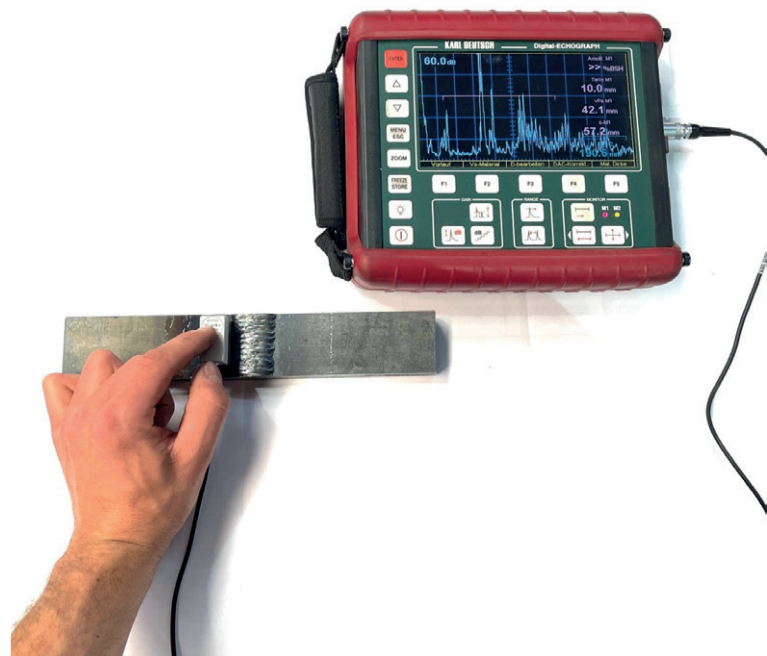

## Non-destructive testing

Various facilities of in-house quality control

- Ultrasonic tests
- Magnetic particle tests
- Dye penetrant tests



## Services



### Automated manufacturing

These are the main points:

- Focused Investment
- High-speed manufacturing
- Key innovation
- High quality products



### Bespoke Systems

- Spade connection
- Cast and fabricated connection parts
- Welding parts
- Modified turnbuckle and cross coupler solutions



### Engineering Support

Our team can provide support and advice for multitude of services:

- Stressing
- Installation
- Misalignment



### Site Services

Equipment hire for tensioning including hydraulic jacks, torque wrenches and strain gauges

## Pre-Stressing

The HMR Jacob Pre-Stresser allows you to induce the required load while using a turnbuckle on the tendons during the pre-stressing operation.

How it works:

The clamps will be positioned on the bar threads on either side of the turnbuckle, pulling the bars into tension and loosen the turnbuckle. The turnbuckle can then be tightened with a chain, strap or stilson wrench.





## Haslinger Group – Products & Services

### Metal & Steel Construction

- Complete service: onsite measurement, 3D planning, fabrication, coating, installation
- EXC4 welding technology
- Structures: platforms, walkways, stairs & railings, passageways, rack systems, canopies, steel halls, heavy-duty and custom constructions

### Cranes & Lifting Technology

- Single- and double-girder bridge cranes, suspension cranes
- Automated & grab cranes, console & slewing cranes
- Custom lifting beams
- Modernisation, radio remote control systems
- Safety inspections (UVV) & crane operator training

### PV Parking Canopies (Solar Carports)

- Steel structures for photovoltaic carports & parking deck canopies
- Structural design, fabrication, and installation from a single source
- Ideal for commercial sites, municipalities, and large parking areas
- Optional integration: drainage, cable routing, EV charging infrastructure

### HMR Jacob – Steel Technology for Timber Construction

- Dowel bars (6–36 mm) and shear connectors (6–22 mm), incl. stainless steel
- Welded components & custom steel parts up to EXC4
- Glulam press systems

### Industrial Services

- Powder coating (up to 13 × 3.5 × 2.5 m, C5 long-term, 200+ colours)
- Wet painting (up to 40 m, ZTV-Ing optional)
- Fire protection coating
- Blasting & cutting technology: 2D laser, plasma, oxy-fuel, and 3D plasma cutting for beams/pipes



#### HMR Jacob GmbH Metallwaren

Industriestraße 5      Tel. +49 99 32 95 37-0  
94486 Osterhofen      info@hmr-jacob.de  
Germany

[hmr-jacob.de](http://hmr-jacob.de)



#### Haslinger Firmengruppe

Gewerbefeld 2      Tel. +49 8543 96 18-0  
94501 Aldersbach      info@haslinger.group  
Germany

[metallbau-haslinger.de](http://metallbau-haslinger.de)